



TIL-TEK Antennae



Solutions that Work



Affordable Quality



ISO 9001:2000



Reliability



Service



**TIL-TEK Antennae Inc.
P.O. Box 550
Kemptonville, Ontario
Canada
K0G 1J0**

December 7, 2006



Quality Management System (QMS):

As a leading supplier of communications solutions to a global marketplace, TIL-TEK is committed to achieving the highest possible quality in all of its products and services. Both our Manufacturing and Research & Development facilities in Canada are ISO 9001:2000 compliant and have been certified since 1996.

Quality is one of the cornerstones of customer value along with innovation, cost and service/support. All product leaves the plant having gone through a rigorous process with a final verification stamp indicating conformance to that process. TIL-TEK is an ISO 9001:2000 registered company. This worldwide standard covers our entire operation of the company from order entry to shipping, from product design to production. Quality will never be compromised either over the long term or for short term convenience.

TIL-TEK's Quality Management System (QMS) provides the guidance and controls for an effective process management system. By implementing and maintaining the QMS, we will consistently provide product that meets customer and applicable regulatory requirements.

Quality Policy:

TIL-TEK will strive to provide our customer with products and services that ensure a high level of customer loyalty and satisfaction. We are committed to a Quality Management System that supports and encourages a culture of customer focus, teamwork, continuous improvement and standards of excellence.

Quality Objectives:

Management has ensured its quality objectives are established and communicated within the company. The Quality Objectives are measurable and consistent with TIL-TEK's Quality Policy and include the requirements needed for planning product realization.

TIL-TEK is committed to:

- * Customer loyalty and satisfaction.
- * Product quality, delivery and service.
- * Continuous improvement of the Quality Management System.
- * Teamwork and standards of excellence.

2005-12-22

Warranty

The specifications on our product data sheets are for reference purposes only and may change at any time without prior notice. For exact specifications, the factory or an authorized representative should be contacted.

TIL-TEK products are warranted against defects in material and workmanship under normal use for a period of three years from the date of shipment from the factory. Authorization must be obtained from TIL-TEK prior to returning a product for warranty service and the product must be returned to TIL-TEK with all transportation charges prepaid. See RMA policy for details.

Warranty repair or replacement without charge will be made only after inspection at the factory shows a defect in material or workmanship. TIL-TEK will pay the return transportation charges, but all other expenses including duty, taxes, storage and all other transaction fees shall be paid by the customer. The warranty period shall not be extended beyond its original term with respect to any part or parts repaired or replaced by TIL-TEK.

TIL-TEK is in no event liable for consequential damages or other costs of any nature resulting from the use of the products it manufactures. TIL-TEK is not liable for replacement from the use of any products damaged by lightning. TIL-TEK is not liable for delays in or inability to fulfill contractual obligations when the causes thereof are beyond the reasonable control of TIL-TEK. TIL-TEK neither assumes nor authorizes any person to assume for it, any obligation or liability other than as herein expressly stated.

This limited warranty is in lieu of all other warranties, either expressed or implied.

2005-12-22

Return Material Authorization (RMA) Policy

TIL-TEK products are warranted against defects in material and workmanship under normal use for a period of three years from the date of shipment from the factory. A RMA number must be obtained from TIL-TEK prior to returning a product for warranty service. The product must be returned to TIL-TEK with all transportation charges prepaid.

Defective Antenna: Provided an antenna is found to be defective under the terms of the warranty, TIL-TEK will repair, replace and return the antenna at no charge to the customer.

No Fault Found: If, after evaluation, the antenna is found to still meet TIL-TEK's electrical and mechanical specifications:

- 1) The customer shall incur an evaluation charge of 25% of the list price or a minimum fee of \$80.00 CDN.
- 2) The customer is responsible to incur the return freight. The antenna will be returned via freight collect.

Note: If an advance replacement is sent and the returned antenna is found to have no fault, the customer will be invoiced for the new replacement and will incur the freight to have the antenna returned to them.

Products



TA-700 Series	698-806 MHz
TA-800 Series	806-960 MHz
TA-900 Series	901-940 MHz
TA-1400 Series	1425-1535 MHz
TA-1800 Series	1850-1990 MHz
TA-1880 Series	1880-1930 MHz
TA-2100 Series	2150-2700 MHz
TA-2300 Series	2300-2500 MHz
TA-2400 Series	2400-2483 MHz
TA-2500 Series	2485-2690 MHz
TA-3400 Series	3400-3700 MHz
TA-4900 Series	4940-4990 MHz
TA-5200 Series	5250-5875 MHz
TA-5400 Series	5470-5875 MHz
TA-5700 Series	5725-5875 MHz

2006-01-31

TA-2004-2-90 Vertical Sector

2052-2083 MHz



The TA-2004-2-90 is a vertically polarized 90 degree sectoral antenna. The antenna consists of a printed dipole array enclosed in an aluminum base with a UV stabilized radome for superior weatherability. The antenna is at DC ground to aid in lightning protection.

Electrical Specifications

Frequency Range: 2052-2083 MHz
Gain: 14.5 dBi
VSWR: 1.5:1
Front to Back Ratio: 20 dB min.
Polarization: Vertical
Power Rating: 100 Watts
H-Plane Beamwidth: 90 degrees
E-Plane Beamwidth: 7.2 degrees
Electrical Downtilt: 0°
Cross Pol. Discrimination: 20 dB min.
Impedance: 50 ohms nominal
Termination: N female

Typical mid band values. (For details , contact factory)
 Specifications subject to change without notice

Mechanical Specifications

Length: 40 in. (1016 mm)
Width: 4.9 in. (124 mm)
Depth: 4.6 in. (117 mm)
Weight (incl. Clamps): 8 lb. (3.6 kg)
Rated Wind Velocity: 125 mph (200 km/h)
Hor. Thrust at rated wind: 86 lb. (39 kg)
Mechanical Tilt: 0 - 15 degrees
Mounting (O.D.): 0.75 - 3.0 in. (19 - 76 mm)

Materials

Radiating Elements: Plated copper on PCB
Reflector: Irridited aluminum
Radome: Gray UV stabilized ASA
Clamps: HDG steel

H-Plane

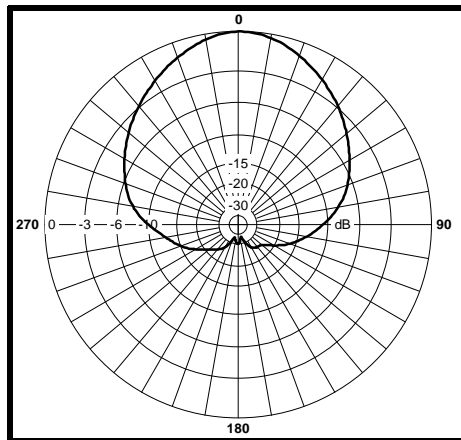

E-Plane

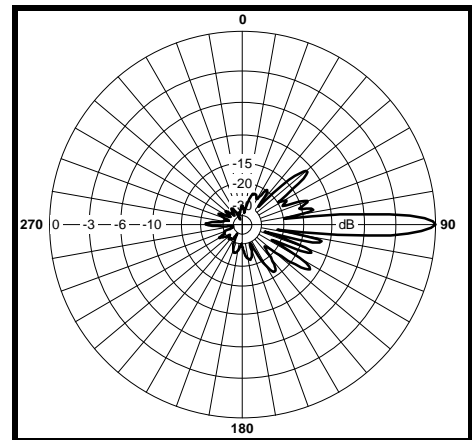

TA-2050 Omnidirectional 2025-2110 Mhz

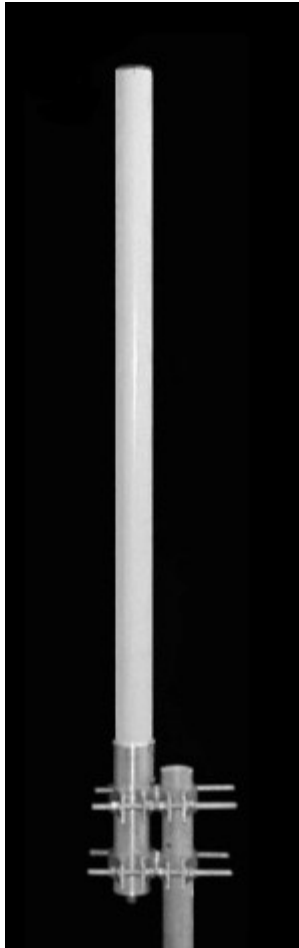

The TA-2050 is a 10 dBi omnidirectional antenna consisting of center fed colinear dipoles in a UV stabilized fiberglass radome. The antenna is designed for severe weather conditions and is at DC ground to aid in lightning protection.

Electrical Specifications

Frequency Range: 2025-2110 Mhz
Gain: 10 dBi
VSWR: 1.5:1 max.
Polarization: Vertical
Power Rating: 150 Watts
H-Plane Beamwidth: 360 degrees
E-Plane Beamwidth: 8.5 degrees
Electrical Downtilt: 0, 4 degrees
Cross Pol. Discrimination: 13 dB typ.
Impedance: 50 ohms nominal
Termination: N female (7/16 DIN optional)

Typical mid band values. (For details , contact factory)
 Specifications subject to change without notice

Mechanical Specifications

Length: 57 in. (1448 mm)
Diameter: 2.25 in. (57 mm)
Weight (Incl. Clamps): 17 lb. (7.7 kg)
Rated Wind Velocity: 125 mph (200 km/h)
Hor. Thrust at rated wind: 37 lb. (16.8 kg)
Mounting (O.D.): 1.75 - 4.0 in. (44.5 - 102 mm)

Materials

Radiating Elements: Copper
Radome: Gray UV stabilized fiberglass
Clamps: HDG and EDZ Steel

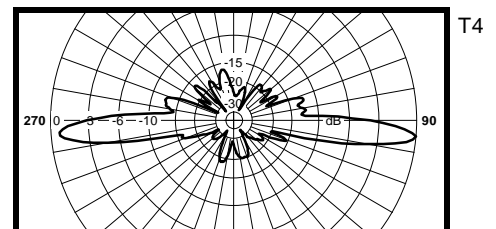
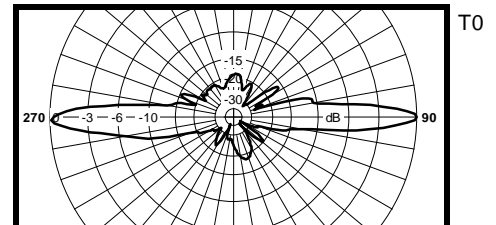

TA-2104-12-90 Sector

2150-2350 or 2500-2700 MHz



The TA-2104-12-90 is a broadband vertically polarized 90 degree sectoral antenna. It was designed specifically for applications requiring superior functionality to maximize overall system performance. Radiating elements are protected by a weatherproof radome for operation under severe weather conditions and are at DC ground to aid in lightning protection.

Electrical Specifications

Frequency Range: 2150-2350 or 2500-2700 MHz
Gain: 16.5 +/- 1 dBi
VSWR: 1.5:1 max.
Front to Back Ratio: 30 dB min.
Polarization: Vertical
Power Rating: 200 Watts
H-Plane Beamwidth: 85° min.
E-Plane Beamwidth: 7° min.
Electrical Downtilt: 0.5° +/- 0.5°
Cross Pol. Discrimination: 20 dB (0° - 90°)
 28 dB (90° - 135°)
 32 dB (135°-180°)
Impedance: 50 ohms nominal
Termination: 7/16 DIN female

Typical mid band values. (For details , contact factory)
 Specifications subject to change without notice

Mechanical Specifications

Length: 49 in. (1245 mm)
Width: 17 in. (432 mm)
Depth: 5 in. (127 mm)
Weight (incl. Clamps): 22 lb. (10.5 kg)
Rated Wind Velocity: 125 mph (200 km/h)
Hor. Thrust at rated wind: 238 lb. (108 kg)
Mechanical Tilt: 0 - 15 degrees
Mounting (O.D.): 1.0 - 3.5 in. (25.4 - 89 mm)

Materials

Radiating Elements: Tin plated copper on PCB
Reflector: Irridited aluminum
Radome: Gray UV stabilized plastic
Clamps: Aluminum and HDG steel

H-Plane

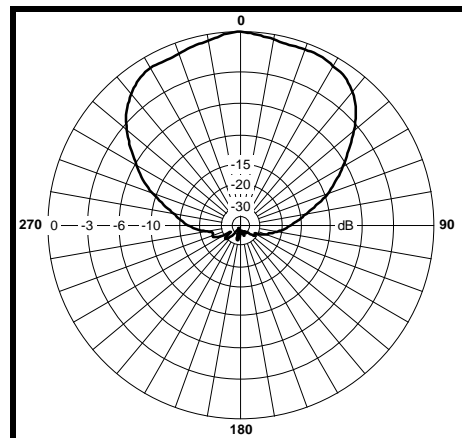

E-Plane

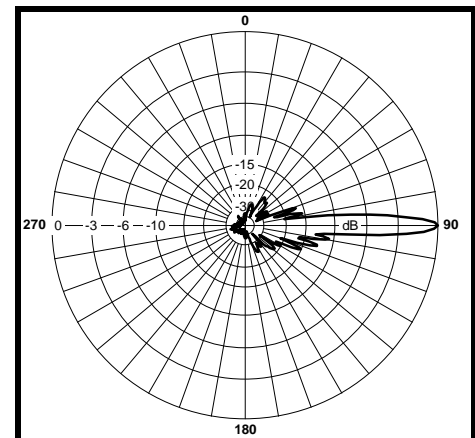

TA-2104-16-90 Sector

2150-2350 or 2500-2700 MHz



The TA-2104-16-90 is a broadband vertically polarized 90 degree sectoral antenna. It was designed specifically for applications requiring superior functionality to maximize overall system performance. Radiating elements are protected by a weatherproof radome for operation under severe weather conditions and are at DC ground to aid in lightning protection.

Electrical Specifications

Frequency Range: 2150-2350 or 2500-2700 MHz
Gain: 17.5 +/- 1 dBi
VSWR: 1.5:1 max.
Front to Back Ratio: 30 dB min.
Polarization: Vertical
Power Rating: 200 Watts
H-Plane Beamwidth: 85° min.
E-Plane Beamwidth: 5° min.
Electrical Downtilt: 0.5° +/- 0.5°
Cross Pol. Discrimination: 20 dB (0° - 90°)
 28 dB (90° - 135°)
 32 dB (135°-180°)
Impedance: 50 ohms nominal
Termination: 7/16 DIN female

Typical mid band values. (For details , contact factory)
 Specifications subject to change without notice

Mechanical Specifications

Length: 64 in. (1626 mm)
Width: 17 in. (432 mm)
Depth: 5 in. (127 mm)
Weight (incl. Clamps): 28 lb. (12.7 kg)
Rated Wind Velocity: 125 mph (200 km/h)
Hor. Thrust at rated wind: 316 lb. (143 kg)
Mechanical Tilt: 0 - 15 degrees
Mounting (O.D.): 1.0 - 3.5 in. (25.4 - 89 mm)

Materials

Radiating Elements: Tin plated copper on PCB
Reflector: Irridited aluminum
Radome: Gray UV stabilized plastic
Clamps: Aluminum and HDG steel

H-Plane

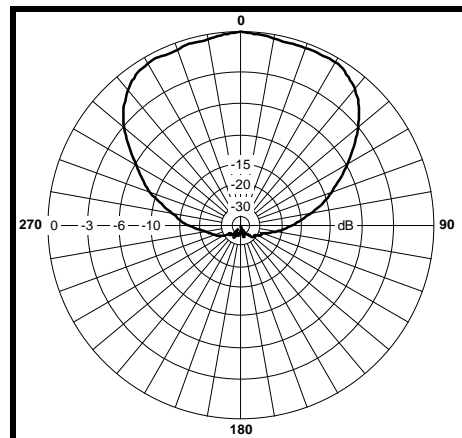

E-Plane

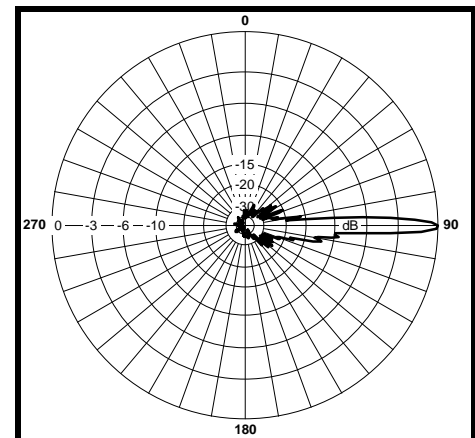

TA-2105H-10-45 Sector

2150-2350 / 2500-2700 MHz



The TA-2105H-10-45 is a horizontally polarized 45 degree sectoral antenna. It was designed specifically for applications requiring superior functionality to maximize overall system performance. The antenna consists of a printed dipole array enclosed in an aluminum base with a UV stabilized radome for superior weatherability. The antenna is at DC ground to aid in lightning protection.

Electrical Specifications

Frequency Range: 2150-2350 / 2500-2700 MHz
Gain: 17 dBi min.
VSWR: 1.5:1 max.
Front to Back Ratio: 30 dB (-67° to +67°)
Polarization: Horizontal
Power Rating: 25 Watts
H-Plane Beamwidth: 11° +/- 1.5°
E-Plane Beamwidth: 40° +/- 5°
Cross Pol. Discrimination: 20 dB min.
Impedance: 50 ohms nominal
Termination: 7/16 DIN female

Typical mid band values. (For details , contact factory)
 Specifications subject to change without notice

Mechanical Specifications

Length: 38.5 in. (978 mm)
Width: 18 in. (457 mm)
Depth: 3 in. (76 mm)
Weight (incl. Clamps): 22 lb. (10 kg)
Rated Wind Velocity: 125 mph (200 km/h)
Hor. Thrust at rated wind: 300 lb. (136 kg)
Mechanical Tilt: 0 - 15 degrees
Mounting (O.D.): 1.0 - 3.5 in. (25.4 - 89 mm)

Materials

Radiating Elements: Tin plated copper on PCB
Reflector: Irridited aluminum
Radome: Gray UV stabilized ASA
Clamps: Aluminum and HDG steel

E-Plane

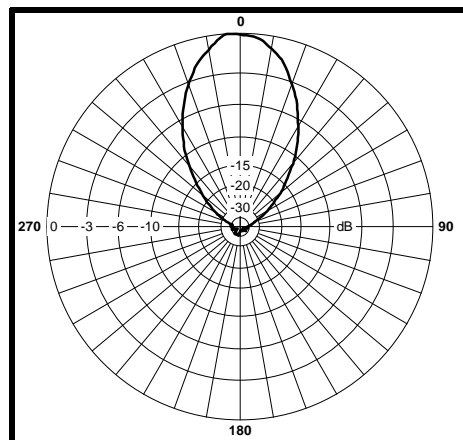

H-Plane

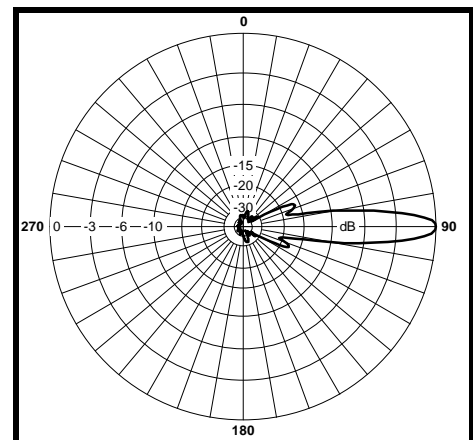

TA-2105H-12-90 Sector

2150-2350 or 2500-2700 MHz



The TA-2105H-12-90 is a broadband horizontally polarized 90 degree sectoral antenna. It was designed specifically for applications requiring superior functionality to maximize overall system performance. Radiating elements are protected by a weatherproof radome for operation under severe weather conditions and are at DC ground to aid in lightning protection.

Electrical Specifications

Frequency Range: 2150-2350 or 2500-2700 MHz
Gain: 16 +/- 1 dBi
VSWR: 1.5:1 max.
Front to Back Ratio: 30 dB min.
Polarization: Horizontal
Power Rating: 200 Watts
H-Plane Beamwidth: 7° min.
E-Plane Beamwidth: 85° min.
Electrical Downtilt: 0.5° +/- 0.5°
Cross Pol. Discrimination: 20 dB (0° - 90°)
 28 dB (90° - 135°)
 32 dB (135°-180°)
Impedance: 50 ohms nominal
Termination: 7/16 DIN female

Typical mid band values. (For details , contact factory)
 Specifications subject to change without notice

Mechanical Specifications

Length: 49 in. (1245 mm)
Width: 17 in. (432 mm)
Depth: 5 in. (127 mm)
Weight (incl. Clamps): 23 lb. (10.5 kg)
Rated Wind Velocity: 125 mph (200 km/h)
Hor. Thrust at rated wind: 238 lb. (108 kg)
Mechanical Tilt: 0 - 15 degrees
Mounting (O.D.): 1.0 - 3.5 in. (25.4 - 89 mm)

Materials

Radiating Elements: Tin plated copper on PCB
Reflector: Irridited aluminum
Radome: Gray UV stabilized plastic
Clamps: Aluminum and HDG steel

E-Plane

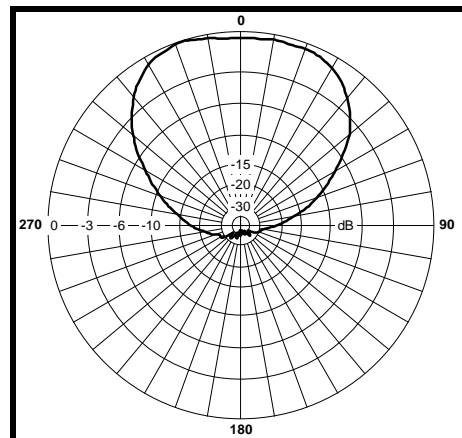

H-Plane

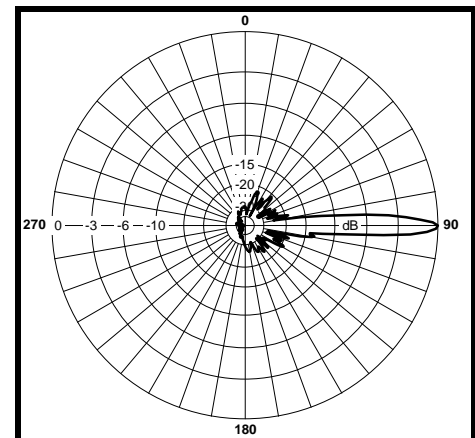

TA-2105H-16-90 Sector

2150-2350 or 2500-2700 MHz



The TA-2105H-16-90 is a broadband horizontally polarized 90 degree sectoral antenna. It was designed specifically for applications requiring superior functionality to maximize overall system performance. Radiating elements are protected by a weatherproof radome for operation under severe weather conditions and are at DC ground to aid in lightning protection.

Electrical Specifications

Frequency Range: 2150-2350 or 2500-2700 MHz
Gain: 17.5 +/- 1 dBi
VSWR: 1.5:1 max.
Front to Back Ratio: 30 dB min.
Polarization: Horizontal
Power Rating: 200 Watts
H-Plane Beamwidth: 5° min.
E-Plane Beamwidth: 85° min.
Electrical Downtilt: 0.5° +/- 0.5°
Cross Pol. Discrimination: 20 dB (0° - 90°)
 28 dB (90° - 135°)
 32 dB (135°-180°)
Impedance: 50 ohms nominal
Termination: 7/16 DIN female

Typical mid band values. (For details , contact factory)
 Specifications subject to change without notice

Mechanical Specifications

Length: 64 in. (1626 mm)
Width: 17 in. (432 mm)
Depth: 5 in. (127 mm)
Weight (incl. Clamps): 28 lb. (12.7 kg)
Rated Wind Velocity: 125 mph (200 km/h)
Hor. Thrust at rated wind: 316 lb. (143 kg)
Mechanical Tilt: 0 - 15 degrees
Mounting (O.D.): 1.0 - 3.5 in. (25.4 - 89 mm)

Materials

Radiating Elements: Tin plated copper on PCB
Reflector: Irridited aluminum
Radome: Gray UV stabilized plastic
Clamps: Aluminum and HDG steel

E-Plane

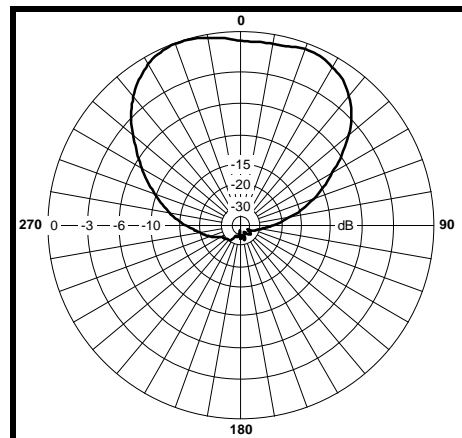

H-Plane

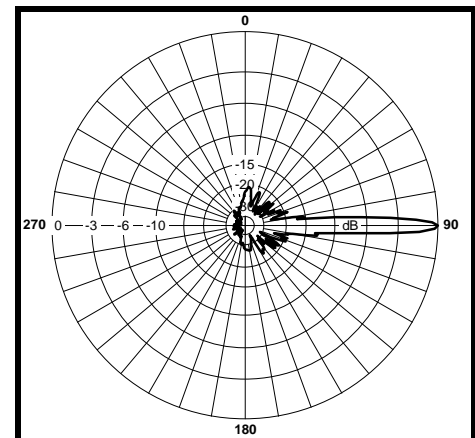

TA-2107 Panel

2150-2350 MHz



The TA-2107 is a vertically or horizontally polarized panel antenna, designed specifically for applications requiring superior functionality to maximize overall system performance. The antenna consists of a printed dipole array enclosed in an aluminum base with a UV stabilized radome for superior weatherability. The antenna is at DC ground to aid in lightning protection.

Electrical Specifications

Frequency Range: 2150-2350 MHz
Gain: 17 dBi min.
VSWR: 1.5:1 max.
Front to Back Ratio: 30 dB min.
Polarization: Vertical or Horizontal
Power Rating: 25 Watts
H-Plane Beamwidth: 20° +/- 2°
E-Plane Beamwidth: 20° +/- 2°
Cross Pol. Discrimination:
 30 dB (+/-34° to +/-45°)
 35 dB (+/-45° to +/-180°)
Impedance: 50 ohms nominal
Termination: 7/16 DIN female

Typical mid band values. (For details , contact factory)
 Specifications subject to change without notice

Mechanical Specifications

Side Length: 18 in. (457 mm)
Diagonal Length: 25.25 in. (641 mm)
Width: 18 in. (457 mm)
Depth: 5.1 in. (130 mm)
Weight (incl. Clamps): 13 lb. (5.9 kg)
Rated Wind Velocity: 125 mph (200 km/h)
Hor. Thrust at rated wind: 83 lb. (37.6 kg)
Mechanical Tilt: 0 - 10 degrees
Mounting (O.D.): 1.0 - 3.5 in. (25.4 - 89 mm)

Materials

Radiating Elements: Plated copper on PCB
Reflector: Irridited aluminum
Radome: Gray UV stabilized ASA
Clamps: Aluminum and HDG steel

H-Plane

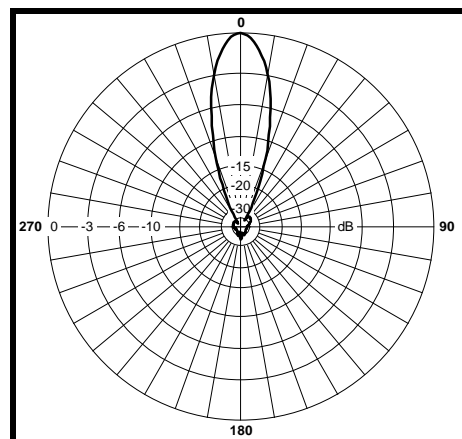

E-Plane

