



# TIL-TEK Antennae



**Solutions that Work**



**Affordable Quality**



**ISO 9001:2000**



**Reliability**



**Service**



**TIL-TEK Antennae Inc.  
P.O. Box 550  
Kemptonville, Ontario  
Canada  
K0G 1J0**

December 7, 2006



## Quality Management System (QMS):

As a leading supplier of communications solutions to a global marketplace, TIL-TEK is committed to achieving the highest possible quality in all of its products and services. Both our Manufacturing and Research & Development facilities in Canada are ISO 9001:2000 compliant and have been certified since 1996.

Quality is one of the cornerstones of customer value along with innovation, cost and service/support. All product leaves the plant having gone through a rigorous process with a final verification stamp indicating conformance to that process. TIL-TEK is an ISO 9001:2000 registered company. This worldwide standard covers our entire operation of the company from order entry to shipping, from product design to production. Quality will never be compromised either over the long term or for short term convenience.

TIL-TEK's Quality Management System (QMS) provides the guidance and controls for an effective process management system. By implementing and maintaining the QMS, we will consistently provide product that meets customer and applicable regulatory requirements.

## Quality Policy:

TIL-TEK will strive to provide our customer with products and services that ensure a high level of customer loyalty and satisfaction. We are committed to a Quality Management System that supports and encourages a culture of customer focus, teamwork, continuous improvement and standards of excellence.

## Quality Objectives:

Management has ensured its quality objectives are established and communicated within the company. The Quality Objectives are measurable and consistent with TIL-TEK's Quality Policy and include the requirements needed for planning product realization.

TIL-TEK is committed to:

- \* Customer loyalty and satisfaction.
- \* Product quality, delivery and service.
- \* Continuous improvement of the Quality Management System.
- \* Teamwork and standards of excellence.

2005-12-22

# Warranty

The specifications on our product data sheets are for reference purposes only and may change at any time without prior notice. For exact specifications, the factory or an authorized representative should be contacted.

TIL-TEK products are warranted against defects in material and workmanship under normal use for a period of three years from the date of shipment from the factory. Authorization must be obtained from TIL-TEK prior to returning a product for warranty service and the product must be returned to TIL-TEK with all transportation charges prepaid. See RMA policy for details.

Warranty repair or replacement without charge will be made only after inspection at the factory shows a defect in material or workmanship. TIL-TEK will pay the return transportation charges, but all other expenses including duty, taxes, storage and all other transaction fees shall be paid by the customer. The warranty period shall not be extended beyond its original term with respect to any part or parts repaired or replaced by TIL-TEK.

TIL-TEK is in no event liable for consequential damages or other costs of any nature resulting from the use of the products it manufactures. TIL-TEK is not liable for replacement from the use of any products damaged by lightning. TIL-TEK is not liable for delays in or inability to fulfill contractual obligations when the causes thereof are beyond the reasonable control of TIL-TEK. TIL-TEK neither assumes nor authorizes any person to assume for it, any obligation or liability other than as herein expressly stated.

This limited warranty is in lieu of all other warranties, either expressed or implied.

2005-12-22

## Return Material Authorization (RMA) Policy

TIL-TEK products are warranted against defects in material and workmanship under normal use for a period of three years from the date of shipment from the factory. A RMA number must be obtained from TIL-TEK prior to returning a product for warranty service. The product must be returned to TIL-TEK with all transportation charges prepaid.

Defective Antenna: Provided an antenna is found to be defective under the terms of the warranty, TIL-TEK will repair, replace and return the antenna at no charge to the customer.

No Fault Found: If, after evaluation, the antenna is found to still meet TIL-TEK's electrical and mechanical specifications:

- 1) The customer shall incur an evaluation charge of 25% of the list price or a minimum fee of \$80.00 CDN.
- 2) The customer is responsible to incur the return freight. The antenna will be returned via freight collect.

Note: If an advance replacement is sent and the returned antenna is found to have no fault, the customer will be invoiced for the new replacement and will incur the freight to have the antenna returned to them.

## Products



TA-700 Series	698-806 MHz
TA-800 Series	806-960 MHz
TA-900 Series	901-940 MHz
TA-1400 Series	1425-1535 MHz
TA-1800 Series	1850-1990 MHz
TA-1880 Series	1880-1930 MHz
TA-2100 Series	2150-2700 MHz
TA-2300 Series	2300-2500 MHz
TA-2400 Series	2400-2483 MHz
TA-2500 Series	2485-2690 MHz
TA-3400 Series	3400-3700 MHz
TA-4900 Series	4940-4990 MHz
TA-5200 Series	5250-5875 MHz
TA-5400 Series	5470-5875 MHz
TA-5700 Series	5725-5875 MHz

2006-01-31

## TA-1881-4-120 Sector

### 1880-1930 MHz



The TA-1881-4-120 is a vertically polarized 120 degree sectoral antenna designed for DECT and PCS applications requiring medium gain and a relatively broad vertical radiation pattern. The printed circuit radiating assembly and transmission lines are enclosed in an aluminum cavity with a UV stabilized radome for superior weatherability. The antenna is at DC ground to aid in lightning protection.

#### Electrical Specifications

**Frequency Range:** 1880-1930 MHz  
**Gain:** 10.5 dBi  
**VSWR:** 1.5:1 max.  
**Polarization:** Vertical  
**Power Rating:** 10 Watts  
**H-Plane Beamwidth:** 120 degrees  
**E-Plane Beamwidth:** 18 degrees  
**Cross Pol. Discrimination:** 15 dB min.  
**Impedance:** 50 ohms nominal  
**Termination:** N female

Typical mid band values. (For details, contact factory)  
 Specifications subject to change without notice

#### Mechanical Specifications

**Length:** 20.2 in. (513 mm)  
**Width:** 4 in. (102 mm)  
**Depth:** 3.6 in. (92 mm)  
**Weight (incl. Clamps):** 3 lb. (1.4 kg)  
**Rated Wind Velocity:** 125 mph (200 km/h)  
**Hor. Thrust at rated wind:** 35 lb. (15.9 kg)  
**Mechanical Tilt:** 0 - 15 degrees  
**Mounting (O.D.):** 1.0 - 3.5 in. (25.4 - 89 mm)

#### Materials

**Radiating Elements:** Plated copper on PCB  
**Reflector:** Irridated aluminum  
**Radome:** Gray UV stabilized ASA  
**Clamps:** Aluminum and HDG steel

H-Plane

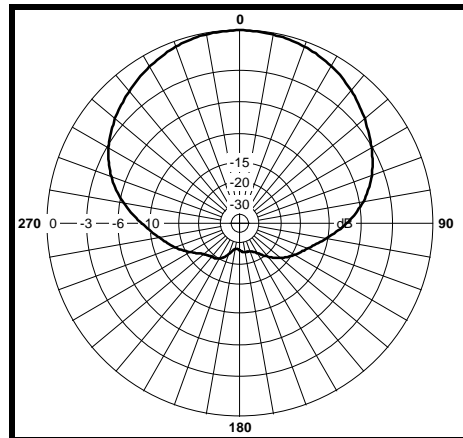

E-Plane

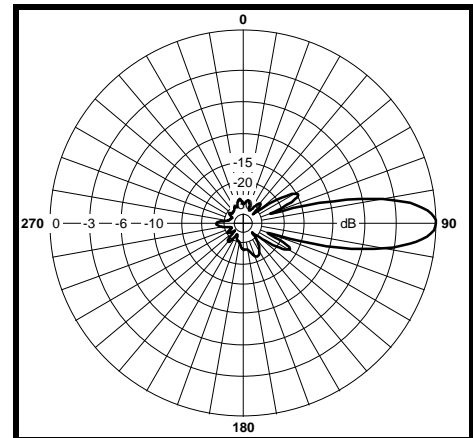

## TA-1882-2-60 Sector 1850-1990 MHz



The TA-1882-2-60 is a vertically polarized 60 degree sectoral antenna, designed for DECT and PCS applications requiring lower gain and a relatively broad vertical radiation pattern. The printed circuit radiating assembly and transmission lines are enclosed in an aluminum cavity with a UV stabilized radome for superior weatherability. The antenna is at DC ground to aid in lightning protection.

### Electrical Specifications

**Frequency Range:** 1850-1990 MHz  
**Gain:** 12 dBi  
**VSWR:** 1.5:1 max.  
**Polarization:** Vertical  
**Power Rating:** 200 Watts  
**H-Plane Beamwidth:** 60 degrees  
**E-Plane Beamwidth:** 25 degrees  
**Cross Pol. Discrimination:** 15 dB min.  
**Impedance:** 50 ohms nominal  
**Termination:** N female

### Mechanical Specifications

**Length:** 11.8 in. (300 mm)  
**Width:** 6.7 in. (170 mm)  
**Depth:** 3.6 in. (92 mm)  
**Weight (incl. Clamps):** 2 lb. (0.9 kg)  
**Rated Wind Velocity:** 125 mph (200 km/h)  
**Hor. Thrust at rated wind:** 46 lb. (21 kg)  
**Mechanical Tilt:** 0 - 30 degrees  
**Mounting (O.D.):** 0.75 - 2.0 in. (19 - 51 mm)

### Materials

**Radiating Elements:** Plated copper on PCB  
**Reflector:** Irridated aluminum  
**Radome:** Gray UV stabilized ASA  
**Clamps:** Aluminum and HDG steel

Typical mid band values. (For details , contact factory)  
 Specifications subject to change without notice

H-Plane

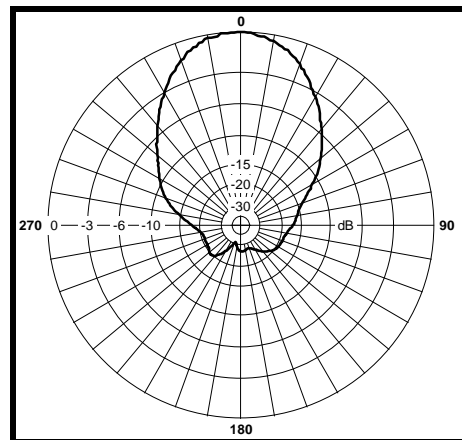

E-Plane

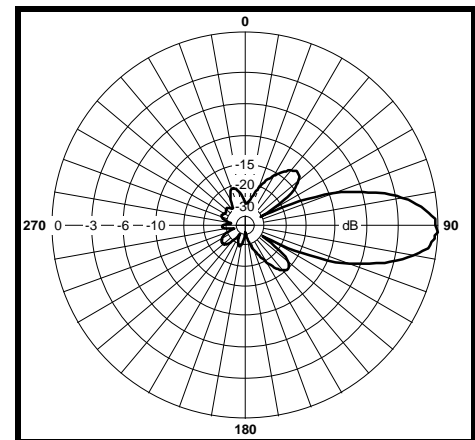

## TA-1882-2-85 Sector

### 1880-1930 MHz



The TA-1882-2-85 is a vertically polarized 85 degree sectoral antenna, designed for DECT and PCS applications requiring lower gain and a relatively broad vertical radiation pattern. The printed circuit radiating assembly and transmission lines are enclosed in an aluminum cavity with a UV stabilized radome for superior weatherability. The antenna is at DC ground to aid in lightning protection.

#### Electrical Specifications

**Frequency Range:** 1880-1930 MHz  
**Gain:** 10.5 dBi  
**VSWR:** 1.5:1 max.  
**Front to Back Ratio:** 20 dB  
**Polarization:** Vertical  
**Power Rating:** 200 Watts  
**H-Plane Beamwidth:** 85 degrees  
**E-Plane Beamwidth:** 25 degrees  
**Cross Pol. Discrimination:** 15 dB min.  
**Impedance:** 50 ohms nominal  
**Termination:** N female

Typical mid band values. (For details , contact factory)  
 Specifications subject to change without notice

#### Mechanical Specifications

**Length:** 11.8 in. (300 mm)  
**Width:** 4.2 in. (102 mm)  
**Depth:** 3.6 in. (92 mm)  
**Weight (incl. Clamps):** 2 lb. (0.9 kg)  
**Rated Wind Velocity:** 125 mph (200 km/h)  
**Hor. Thrust at rated wind:** 18 lb. (8.2 kg)  
**Mechanical Tilt:** 0 - 30 degrees  
**Mounting (O.D.):** 0.75 - 2.0 in. (19 - 51 mm)

#### Materials

**Radiating Elements:** Plated copper on PCB  
**Reflector:** Irridited aluminum  
**Radome:** Gray UV stabilized ASA  
**Clamps:** Aluminum and HDG steel

H-Plane

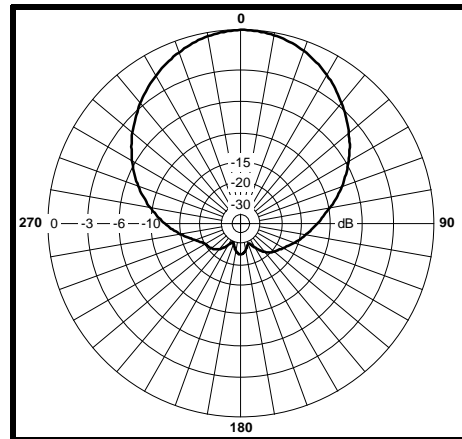

E-Plane

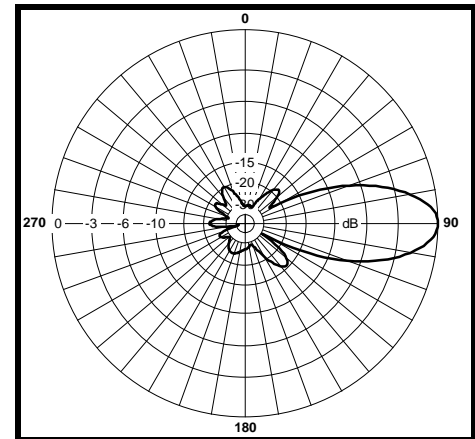

## TA-1882-4-60 Sector 1880-1930 MHz



The TA-1882-4-60 is a vertically polarized 60 degree sectoral antenna, designed for DECT and PCS applications requiring medium gain and a relatively narrow vertical radiation pattern. The printed circuit radiating assembly and transmission lines are enclosed in an aluminum cavity with a UV stabilized radome for superior weatherability. The antenna is at DC ground to aid in lightning protection.

### Electrical Specifications

**Frequency Range:** 1880-1930 MHz  
**Gain:** 15 dBi  
**VSWR:** 1.5:1 max.  
**Front to Back Ratio:** 20 dB  
**Polarization:** Vertical  
**Power Rating:** 200 Watts  
**H-Plane Beamwidth:** 60 degrees  
**E-Plane Beamwidth:** 14.5 degrees  
**Cross Pol. Discrimination:** 15 dB min.  
**Impedance:** 50 ohms nominal  
**Termination:** N female

Typical mid band values. (For details , contact factory)  
 Specifications subject to change without notice

### Mechanical Specifications

**Length:** 23.2 in. (589 mm)  
**Width:** 6.25 in. (161 mm)  
**Depth:** 3.6 in. (92 mm)  
**Weight (incl. Clamps):** 2 lb. (0.9 kg)  
**Rated Wind Velocity:** 125 mph (200 km/h)  
**Hor. Thrust at rated wind:** 85 lb. (38.6 kg)  
**Mechanical Tilt:** 0 - 30 degrees  
**Mounting (O.D.):** 0.75 - 2.0 in. (19 - 51 mm)

### Materials

**Radiating Elements:** Plated copper on PCB  
**Reflector:** Irridited aluminum  
**Radome:** Gray UV stabilized ASA  
**Clamps:** Aluminum and HDG steel

H-Plane

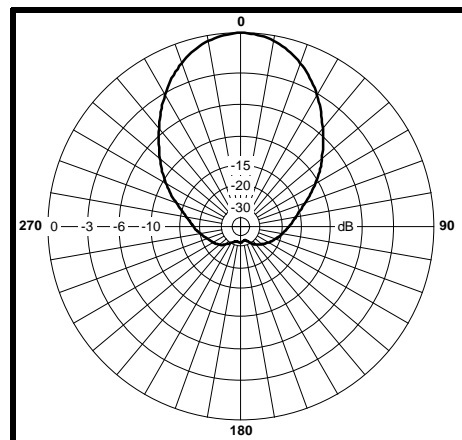

E-Plane

